

CABLE CUTTER

TYPE HCV100

P/N 980292

**INSTRUCTIONS, OPERATION &
MAINTENANCE MANUAL**

Issue Date 05 April 2005

CABLE CUTTER – TYPE HCV100

Description:

The HCV100 cutter is a lightweight cutter designed for cutting umbilical cables & electrical cables, and is capable of being operated remotely in a subsea environment. It may be mounted on an ROV or manipulator arm.

The cable to be cut is retained between an anvil and cutting blade, the anvil is hydraulically withdrawn to allow placement of the cable.

Cutting Capacity:

The HCV100 cutter is primarily intended for cutting soft materials such as umbilical cable, communications cable and electrical power lines (including double wire armoured cables) up to a maximum diameter of 100 mm.

It is not intended for use on high tensile wire rope, chain or solid steel bar.

Where diameters smaller than 100mm are to be cut, every effort should be made to place the material to be cut centrally along the anvil to minimise offset loadings.

NB. IF IN ANY DOUBT ABOUT THE SIZE AND TYPE OF MATERIAL TO BE CUT, PLEASE REFER TO THE MANUFACTURER, FAILURE TO DO SO MAY RESULT IN PERMANENT DAMAGE TO THE CUTTER.

Installation:

Four holes are provided in the tool body, as shown in Fig 1.2, which can be used for any attachment necessary to mount the cutter to an operating arm/vehicle.

Two hydraulic supplies are required, as shown in Fig 1.2. The maximum working pressures are shown in Table 1 below and pressure limiting valves should be incorporated into the supply sources to limit the pressures to the stated levels.

Table 1:

Function	Maximum Working Pressure		Swept Volume ML	Port Tapping NPT
	PSI	BAR		
Main Ram Closing Stroke	9280	640	720	1/4"
Main Ram Return Stroke	9280*	640*	355	1/4"
Auxiliary Cylinder Out Stroke (To Retract The Anvil)	2750	190	30	1/4"
Auxiliary Cylinder In Stroke (To Reset The Anvil)	2750	190	20	1/4"

NB. Actual pressure required to return ram < 15 BAR (217 PSI)

CABLE CUTTER – TYPE HCV100

Operation:

Prior to use the auxiliary cylinder out stroke should be operated to withdraw the anvil, this clears access for the cutter to be placed over the cable.

Place the cutter over the cable. Ensure the cable is as far into the cutter as possible so that the anvil does not foul as it is reset.

Operate the auxiliary cylinder in stroke to position the anvil fully home under the cable.

NB. IT IS IMPORTANT THAT THE AUXILIARY CYLINDERS ARE FULLY STROKED AT THIS STAGE, AS PERMANENT DAMAGE WILL RESULT IF THE ANVIL IS NOT FULLY ENGAGED.

Operate the main ram down stroke to sever the cable, when the cut is complete; retract the main ram until it is fully home. If further cuts are required, the above procedure should be repeated.

NB. DO NOT OPERATE THE AUXILIARY CYLINDERS WHEN THE MAIN RAM IS FULLY EXTENDED, AS THIS WILL DAMAGE THE BLADE AND ANVIL.

After Use Care:

If the cutter has been used in a marine environment, it should be hosed down with clean fresh water, allowed to drain and sprayed externally with a de-watering fluid.

Before storage, inspect the general condition of the cutter paying particular attention to the anvil and blade. The anvil should be clean and free from any damage or bruising on the outside diameter which would prevent it from retracting properly, the blade edge should be smooth and free from any serration's, a slight ripple to the blade edge is acceptable and will not cause any problems. Any minor damage can be smoothed off with an oilstone if necessary.

General Maintenance & Service:

Since the cutters are manufactured with care from high quality materials, little maintenance is necessary, other than to keep the tool clean and free from debris.

It is unlikely that any service would be required on the hydraulic components of the cutter under normal circumstances but a seal kit is available if required. The only other parts that would require intermittent replacement, depending on the frequency of use and materials being cut, would be the anvil and blade. Spares can be ordered using the following part numbers.

Anvil P/N CC6378

Blade P/N 705010

Seal Kit P/N 995291

If required, the cutter can be returned to the manufacturer/supplier at any time for servicing and testing. If the user undertakes servicing, please refer to the paragraph on Proof Testing under the section **Safety** below.

CABLE CUTTER – TYPE HCV100

Safety General:

Whilst the cutter is intended for remote operation subsea, there is no reason why it should not be used on surface and be operated using a suitable hand pump.

In all cases where an operator is present, the safety aspects must be reviewed before any cutting operations commence.

Ensure that the cutter, hoses and pressure source are in good condition, all rated to the maximum working pressure of the cutter and all connected correctly.

No attempt should be made to cut cables or other material, which is under tension.

Ensure the operator is shielded from the cutting blade during the cutting operation. When cutting near the very end of the cable individual pieces of cable may be expelled from the cutter at force, so ensure the operator is shielded from these also.

Safety Proof Testing:

If at any time it is necessary to carry out proof tests on the cutter, e.g. after service on the hydraulic cylinder the following applies.

The maximum proof test pressure must not exceed 125% of the maximum working pressure.

The cutter must be guarded during the proof testing operation.

The proof pressure must be applied gradually, by means of a hand pump, until the maximum pressure is reached.

Anvil & Blade Renewal:

To change the anvil or blade the following procedure should be adopted.

Disconnect the anvil (CC6378) from the anvil bracket (765179) by removing the spring Pin (030820). The anvil should be passed through the body and removed.

To remove the blade (705010), pump out the main ram until the three 1/4" diameter blade-retaining pins (030648) are accessible. Remove the pins using a pin punch and slide the blade out of the cutter.

To replace the anvil or blade, reverse the above operations.

CABLE CUTTER – TYPE HCV100

Table 2: Cutter Parts List – Refer to Fig. 1.1

Part No.	DESCRIPTION	QTY
710177	Main Body	1
728027	Main Cylinder	1
764060	Main Ram	1
774020	Bearing Ring	1
CC6378	Anvil	1
715300	Bush, Anvil Guide	1
715301	Bush, Anvil	1
709047	Block, Sliding	2
765121	Guide Plate, Blade	2
701187	Adapter	1
011011	Bolt, Clevis	2
035061	Screw, Sliding Block	2
080956	Washer	2
705010	Blade	1
025570	Scraper, ram	1*
025756	O-Ring	1*
025803	Seal, Main Cylinder	1*
025804	Seal, Main Ram	1*
035062	Screw, Socket Set, Anvil Bush	1
035080	Screw, Socket Set, Main Cylinder	2
035064	Screw, Socket Cap, Blade Guide	16
030648	Spring Pin, Blade Retaining	3
030820	Spring Pin, Anvil	1
982118	Cylinder, Lever	2
765179	Bracket, Anvil	1
761231	Clevis Pin	1
761230	Pivot Pin	1
761232	Spacer Pin	1
765178	Frame Leg	2
080978	Washer, Spacer Pin	2
035091	Screw, Socket Set, Clevis Pin	2
715335	Bush	4
035092	Screw, Socket Cap, Spacer Pin	2
035073	Screw, Socket Set, Pivot Pin	2

NB. Parts marked * are contained in the seal kit P/N 995291.

CABLE CUTTER – TYPE HCV100

Table 2: Auxiliary Cylinder Parts List – Refer to Fig. 2.1

Part No.	DESCRIPTION	QTY
709606	Piston Block	1
728029	Cylinder Lever	1
SSC6476	End Cap	1
764102	Piston	1
026701	Pellet, Aluminium	1
025311	O-Ring, End Cap	1*
025569	Scraper, Rod	1*
025801	Seal, Piston	1*
025802	Seal, Rod	1*
035062	Screw, Socket Set, Piston Block	1
035063	Screw, Socket Cap, End Cap	4

NB. Parts marked * are contained in the seal kit P/N 995291.

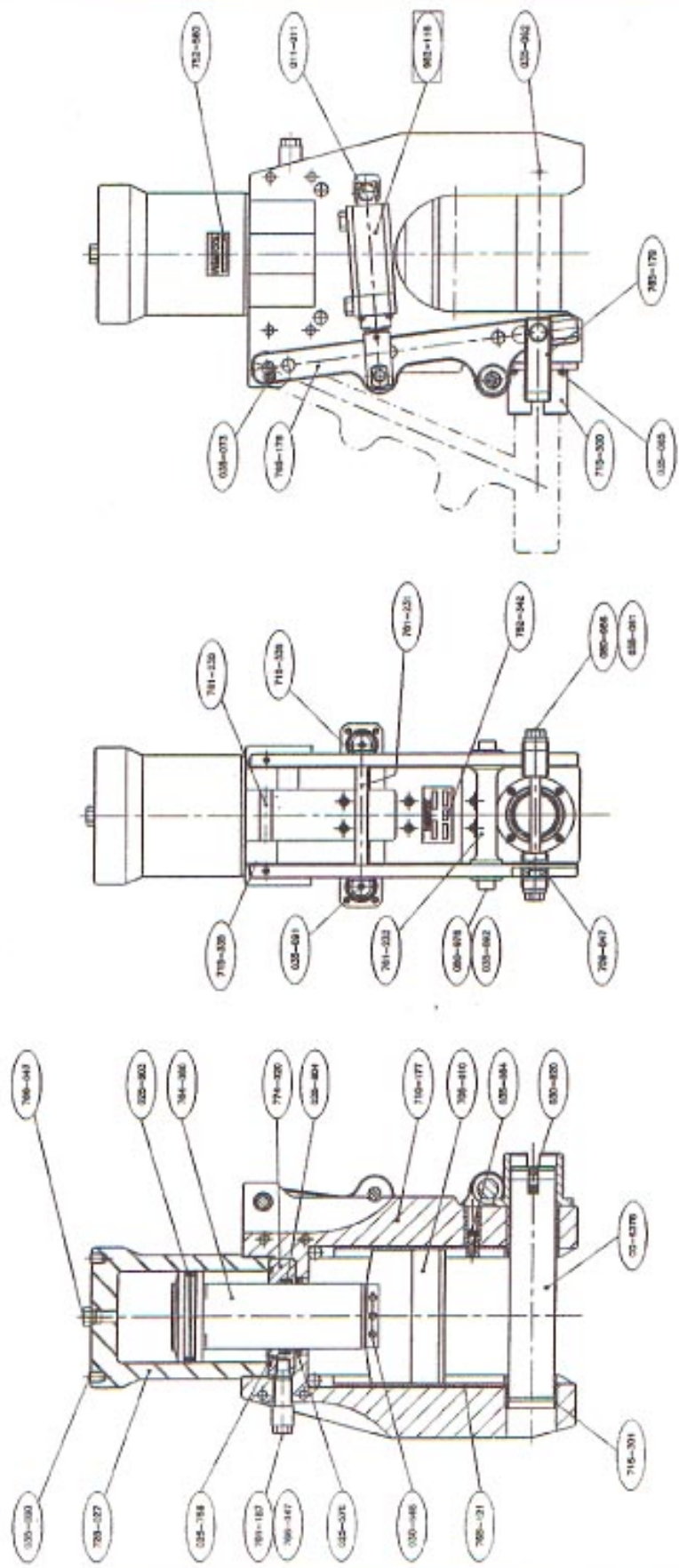

Fig.1.1

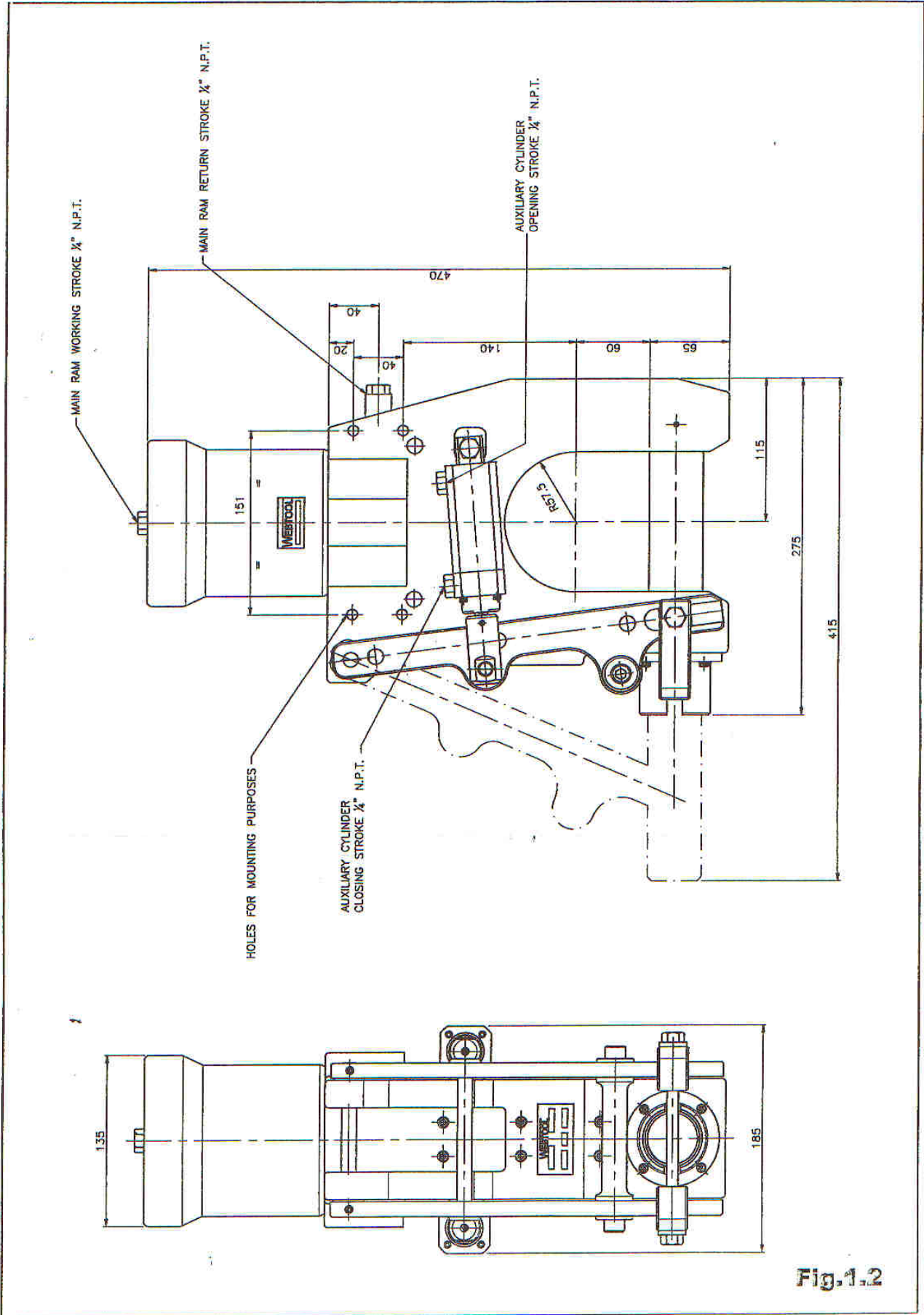

Fig.1.2

Auxiliary Cylinder: 982-118

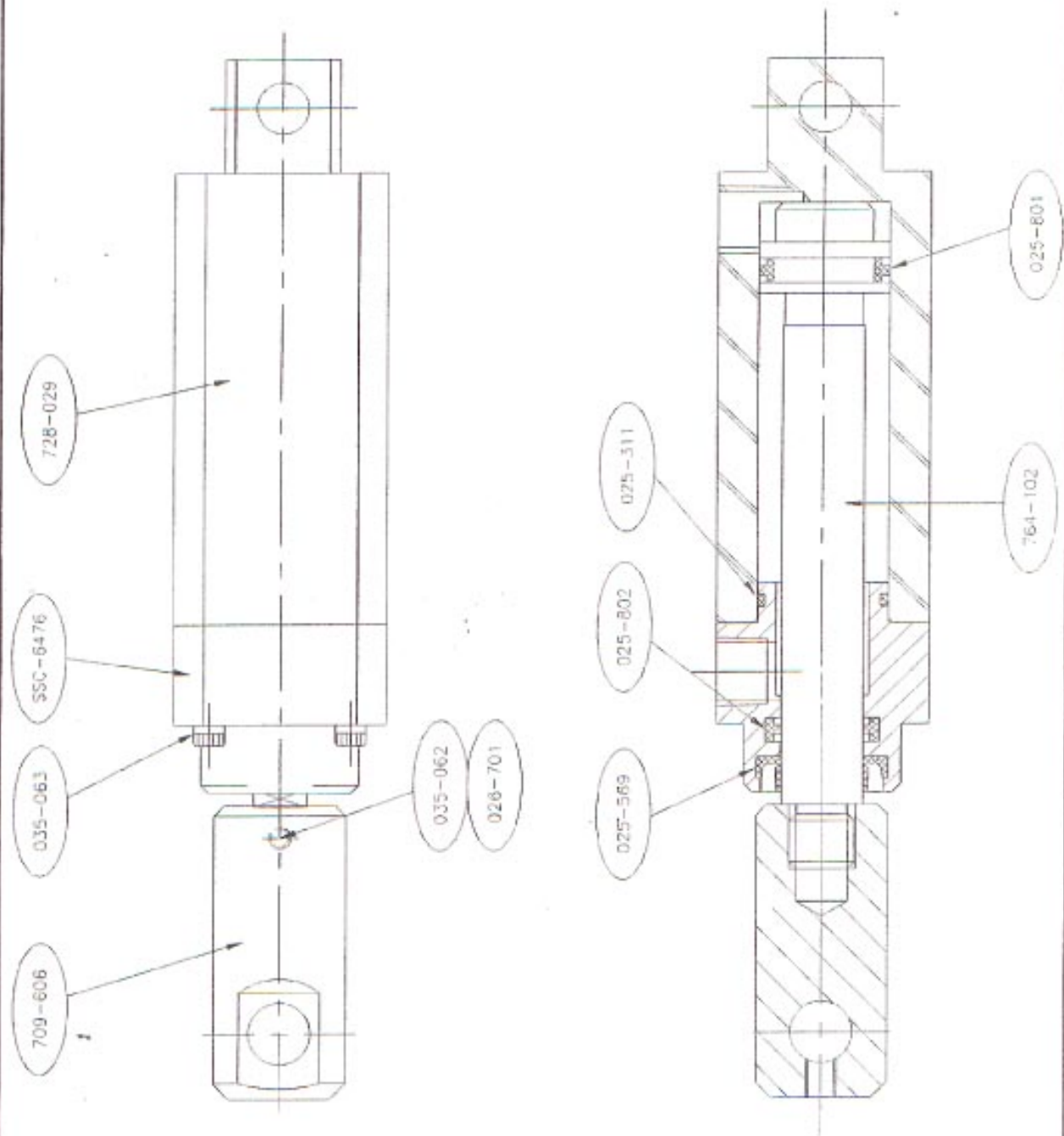

Fig.2.1