

# WEBTOOL

Allspeeds  
Royal Works, Atlas Street  
Clayton le Moors  
Accrington  
Lancashire  
England  
BB5 5LW

Tel:- +44 (0)1254 615100  
[www.allspeeds.co.uk](http://www.allspeeds.co.uk)

**WCS38D**

**WIRE ROPE CUTTER**

**PRODUCT CODE No. 980487**

**INSTRUCTIONS FOR INSTALLATION,  
OPERATION & MAINTENANCE**

Rev 4 Issue 1. 6th October 2011

## Description

The WCS38D is a double acting tool primarily intended for use on steel wire rope, having a maximum tensile strength of 1770N/mm and will cut ropes up to 38mm diameter. It may be used on alternative materials, such as electrical power or communication cables, again up to a maximum of 38mm diameter.

### 1. **SAFETY**

Before operation, read and understand this operations manual.

Whilst the tool is intended for remote or local operation sub-sea, there is no reason why it should not be used above surface.

Ensure that the tool, hoses and pump are in good condition and properly connected.

Ensure that suitable pressure regulation equipment is used and that the unit is not subjected to pressures higher than those stated in section 3

In all cases, where an operator is present, the safety aspects must be reviewed before the cutting operation is commenced.

No attempt should be made to cut wire ropes or other material that is under tension.

Ensure that the operator is shielded from the cutting blade during the cutting operation.

When cutting near the very end of hose or rope, individual cut wires can be expelled from the tool, please ensure that the operator is shielded from these.

If in doubt please contact Wetool for assistance.

If at any time it is necessary to carry out proof tests on the tool, e.g. after service on the hydraulic cylinders, it must be returned to the supplier for testing where the following procedures apply.

The maximum proof test pressure should not exceed 125% of the maximum working pressure and this should only be done by Allspeeds using our specially adapted test rig.

The tool should be guarded during the proof test operation, and be carried out in a safe working environment.

The proof pressure should be applied gradually, until the maximum pressure is reached.

### **INSPECT THE TOOL BEFORE USE**

With the cutter isolated from the hydraulic supply, check the condition of the blade edge. If the blade is damaged or blunt replace with a fresh blade before cutting. This procedure is as described in section 8.

Ensure that care is taken when checking the blade as the edge may be sharp

Check the condition of the anvil. It is normal that the anvil will show an indent where the blade has pressed down into it and can withstand multiple cuts, but any excessively damaged anvil should be replaced. This procedure is as described in section 7

**CAUTION – USE OF BLADES AND PARTS NOT APPROVED BY WEBTOOL MAY RESULT IN TOOL FAILURE AND CONSEQUENTIAL DAMAGE**

**2. CUTTING CAPACITY**

The cutter is primarily intended for use on steel wire rope, having a maximum tensile strength of 1770N/mm and will cut ropes up to 38mm diameter. It may be used on alternative materials, such as electrical power or communication cables, again up to a maximum of 38mm diameter. Where smaller diameters are to be cut, effort should be made to place the material centrally along the anvil to minimise any offset loading. This cutter is not intended for use on chain or solid steel bar.

**3. INSTALLATION**

The cylinder is a pressure vessel and is not recommended as a mounting point, the cylinder should not be drilled, machined, mutilated or damaged in any way, any warranty could be invalidated by such actions.

A hydraulic supply is required, ported as shown (see sketch). The maximum working pressures are shown in the table 1 below and pressure limiting valves must be fitted into the supply to limit the pressures to these levels.

A relief valve should also be incorporated in the return line. This is to prevent excessively high pressures in the annular side of the hydraulic cylinders should the return to tank become blocked for any reason.

The oil supply must be clear and free from contamination. A good quality ISO32 grade hydraulic oil, e.g. Shell Tellus 32 or equivalent, is suitable.

The weight of the tool is 11.5kg.

TABLE 1.

Function	Working Pressure		Swept Volume	
	psi	bar	ml.	U.S. Gallon
Working Stroke	10,000	700	100	(0.027)
Return Stroke	2,750	190	50	(0.014)

Please note: Max working pressure and max return stroke pressure is 700 bar

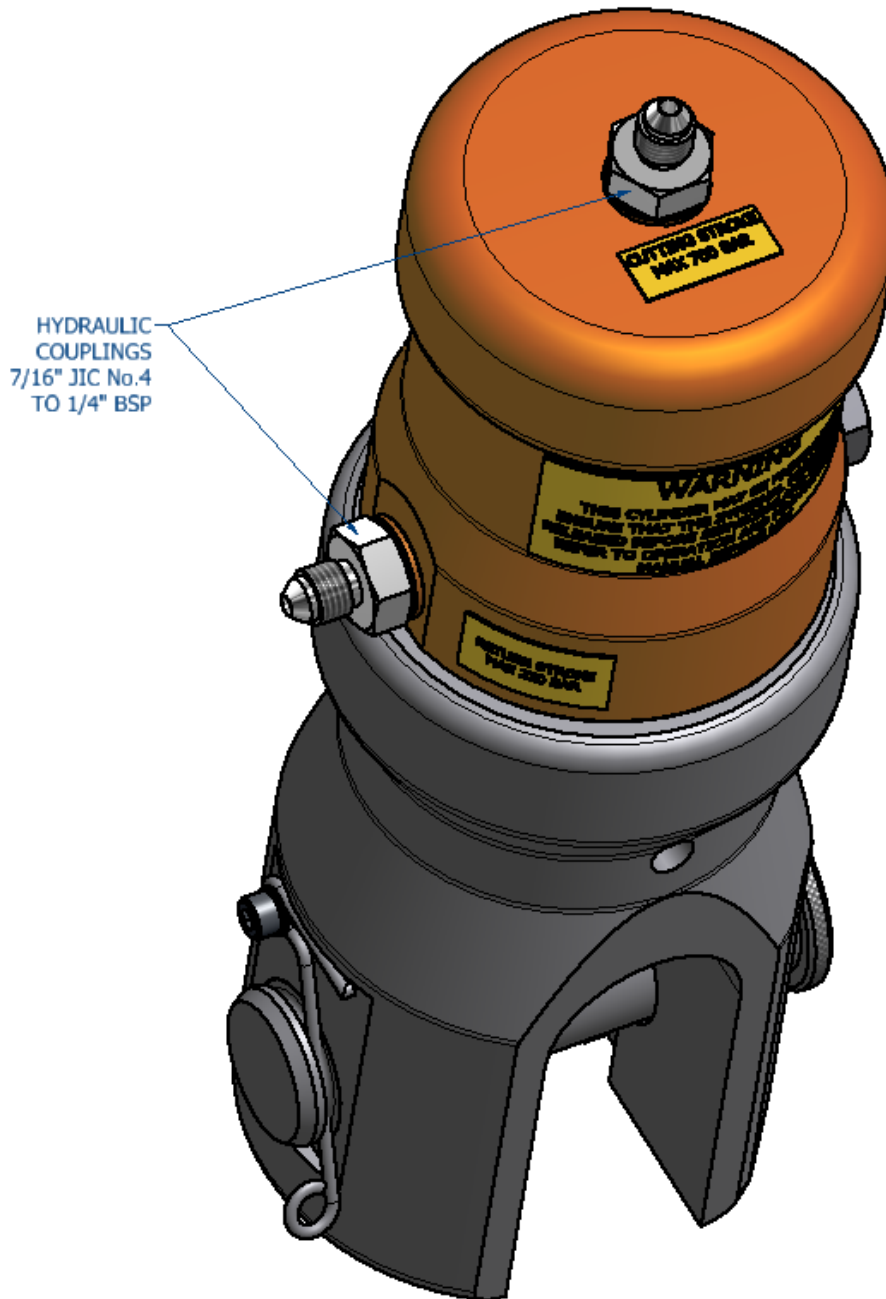

#### 4. OPERATION

Before deployment, function test the tool and ensure that all operators are familiar with this procedure. ROV observation of the tool should be maintained at all time during operation.

Prior to use, ensure no damage has occurred to the blade or anvil.

#### **DEPLOYMENT**

Remove the anvil 761274 by releasing the retaining spring 788064. Place the cutter over the wire rope. Ensure that the wire rope is as far into the cutter as possible.

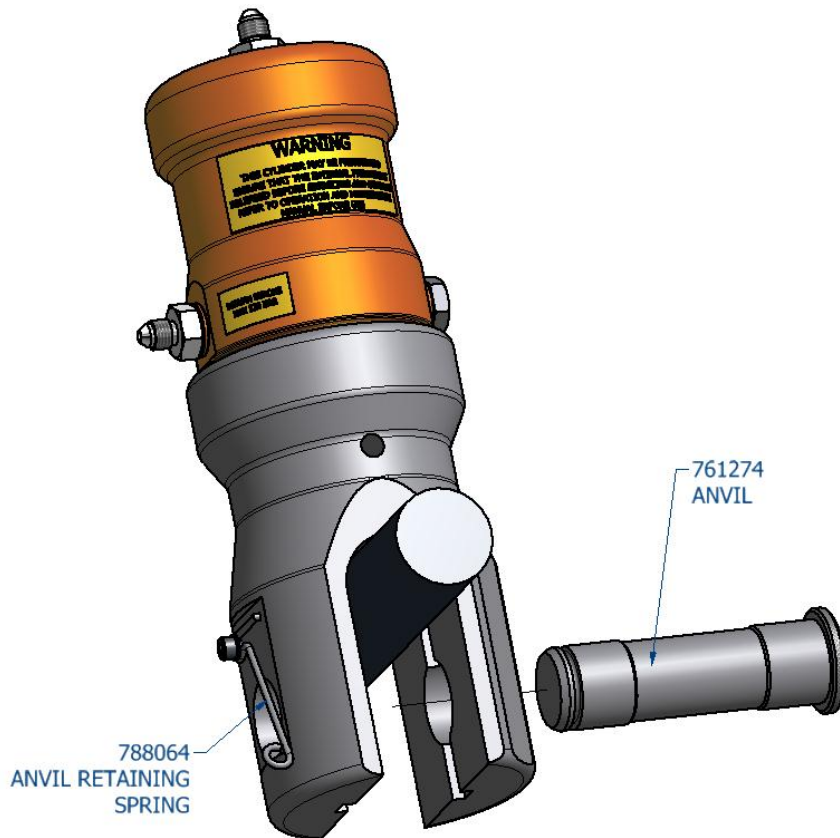

Replace the anvil 761274 and ensure the anvil retaining spring 788064 is located thus retaining the wire rope in the body of the tool. It is important that the anvil is correctly located i.e. the spring is located in the groove in the anvil, this will prevent damage to the tool.

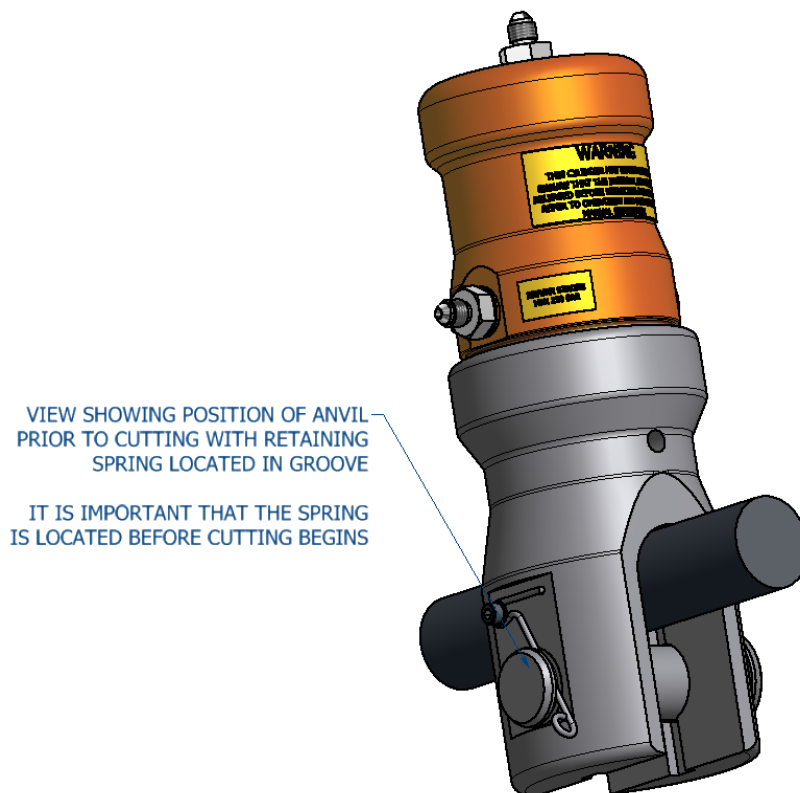

Operate the main ram power port to sever the wire rope, hold pressure until the wire rope is severed.

Once the wire is severed, pressurize the main ram retract port to withdraw the cutting blade.

Do not try to remove the anvil when the blade is fully extended.

If a further cut is required, the above procedure should be repeated.

## **TROUBLESHOOTING**

If the rope does not cut through completely on the first attempt, cycle the blade by retracting it slightly and then attempting the cut again.

If the rope does not completely cut after multiple cycles of the blade, check the input pressure to the main input of the cylinder. This can be a maximum of 700 bar (10,000psi).

If the rope to be cut is still not severed after multiple cycles and at a pressure of 700 bar, retract the blade and then remove the anvil and return the tool to the surface for inspection of the blade and anvil, replace if necessary.

**IMPORTANT NOTE – ENSURE THAT THE BLADE IS FULLY RETRACTED AND THAT ALL PRESSURE TO THE CUTTER IS RELIEVED AS IT IS RAISED TO THE SURFACE. FAILURE TO DO THIS CAN LEAD TO A DANGEROUS BUILD UP OF PRESSURE IN THE CYLINDER.**

## **5. AFTER USE**

When the tool is retrieved from a marine environment, it should be hosed off with clean water, allowed to drain and sprayed externally with a de-watering fluid. Before storage, inspect the general condition of the tool. Particular attention should be paid to the anvil and blade. The anvil should be clean and free from any damage, The blade edge should be smooth and free from any serrations. Note that a slight ripple to the blade edge is acceptable and will not cause problems. Any minor damage can be smoothed off with an oil stone if necessary.

**IMPORTANT – DO NOT STORE THE TOOL WITH A COMPLETELY SEALED CYLINDER AS PRESSURE MAY BUILD UP DUE TO TEMPERATURE CHANGES.**

## **6. SERVICE**

**IMPORTANT – ENSURE THERE IS NO HYDRAULIC PRESSURE IN THE CYLINDER BEFORE PERFORMING ANY SERVICE OR MAINTENANCE PROCEDURES ON THIS CUTTER**

It is unlikely that service would be required on the hydraulic components of the tool under normal circumstances, but a seal spares kit is available if required. The only parts that would need intermittent replacement would be the anvil and blade, depending on the frequency of use and materials being cut. These parts can be ordered up on the following spares reference numbers, but in addition please quote the tool serial number.

Seal Kit	Part Number	995139
Anvil	Part Number	761274
Blade	Part Number	705012C
Blade Retaining Pin	Part Number	030522

We advise that any servicing should be carried out by an authorised distributor only. If required, the tool can be returned to the manufacturer for servicing and testing. If servicing is to be undertaken by the user, please see note on proof testing under SAFETY (Chapter 3), and the following:-

All servicing operations should be carried out in a clean environment to prevent contamination of the oil and mating components.

Care should be taken with all mating areas ie. threads and sealing faces, as any damage or abrasive contamination could cause galling or seizing on re-assembly.

Please note that we coat the stainless steel cylinders with a titanium nitride coating to prevent galling, however, a suitable anti-galling paste should be used (we recommend Swagelok Silver Goop) on all stainless steel threads.

The cylinder is a pressure vessel and should not be drilled, machined, mutilated or damaged in any way for mounting purposes or to assist in its removal for servicing, any warranty could be invalidated by such actions. Also see section 9

The use of stilsons to remove the cylinder is not recommended as damage will occur.

## 7. REPLACEMENT OF THE ANVIL

Pull the anvil retaining spring 788064 out of the anvil groove, this will allow the anvil 761274 to be easily removed from the cutter . If the anvil surface is badly marked it can be rotated to offer up a new surface when further cuts are to be made.

Re-assembly is the reverse of the above process.

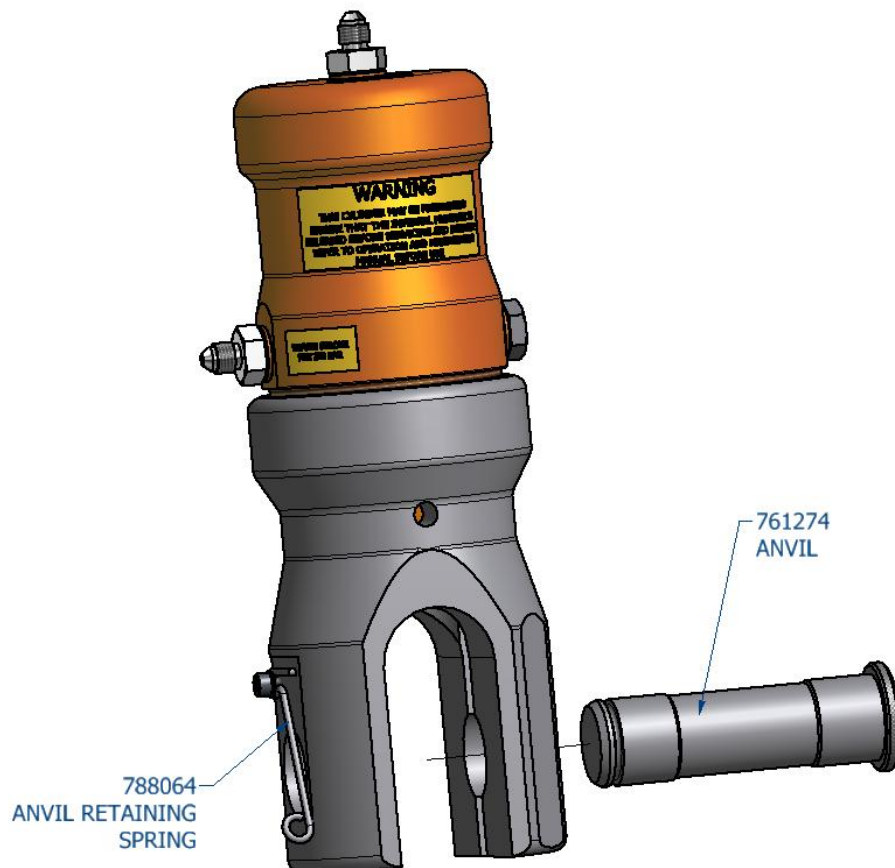

## 8. REPLACEMENT OF THE CUTTING BLADE

First withdraw the anvil as described above.

Pump out the main ram until the blade retaining pin 030522 can be seen in the hole in the cutter body. Drift out the pin 030522 and slide the blade 705012c out of the tool.

Gloves may be worn to protect the hands when removing the blade from the tool.

When refitting the new blade ensure the retaining pin is below the surface of the ram on both sides.

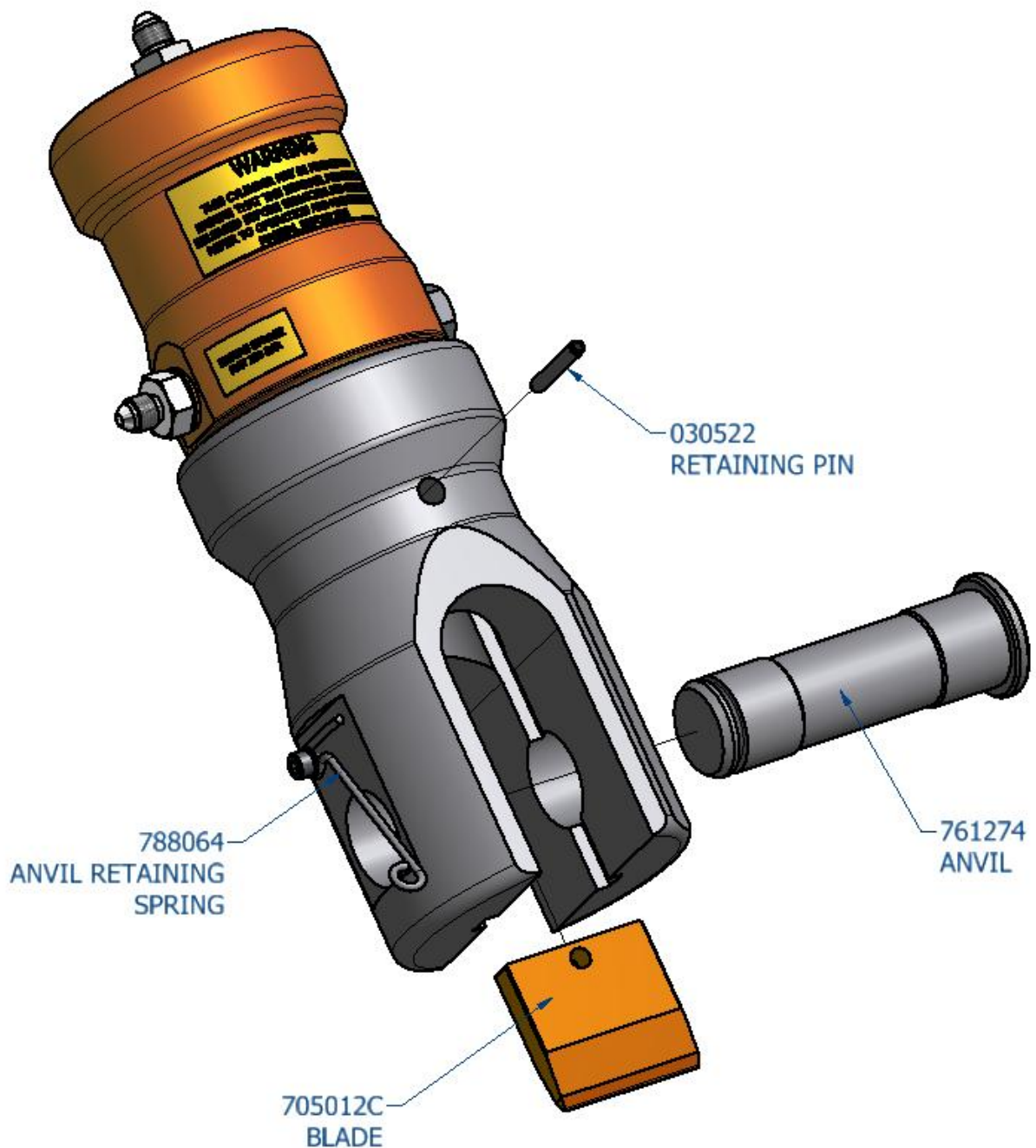

## 9. REMOVAL OF THE MAIN CYLINDER

If it is necessary to renew the hydraulic seals, first remove the blade as described above in section 8, the cylinder must then be removed from the tool. As an aid to this, the hydraulic ports used by 791157 and blanking plug 766084 on the sides of the cylinder 728101 can be used. The hydraulic fittings should first be removed, then a threaded bar is to be screwed into each port, apply a torque and not a bending moment when screwing the cylinder. The thread in the ports is  $\frac{1}{4}$ " BSP. These can be used to loosen or re-tighten the cylinder. The cylinder is a pressure vessel and should not be drilled, machined, mutilated or damaged in any way for mounting purposes or to assist in its removal for servicing, any warranty could be invalidated by such actions. Do not use Stilsons to remove the cylinder as damage will occur.

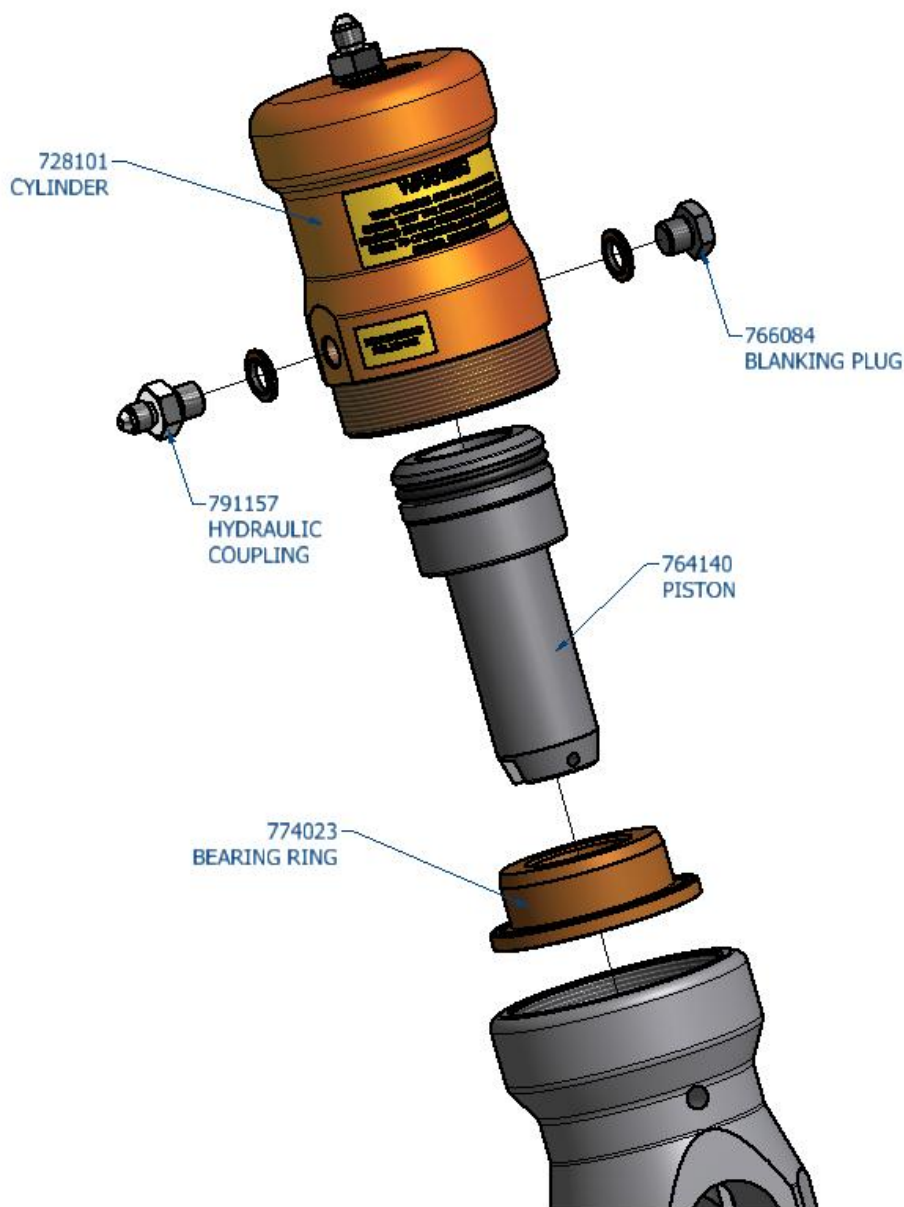

<b>WCS38D – Part List</b>		<b>980487</b>
<b>Part No.</b>	<b>Description</b>	<b>Qty.</b>
710 298	Cutter body	1
728 101	Cylinder	1
764 140	Ram	1
774 023	Bearing ring	1
705 012c	Blade	1
766 084	Blanking plug	1
761 274	Anvil	1
030 522	Blade retaining pin	1
788 064	Anvil retaining spring	1
035 052	Anvil retaining spring screw	1
080 959	Anvil retaining spring washer	1
752 342	Webtool nameplate	1
791 157	Coupling , 7/16" JIC No.4 – ¼" BSP	2
752 573	Pressure warning label	1
752 571	Port pressure label – cutting	1
752 574	Port pressure label – return	1

<b>Cutter Seal Kit</b>		<b>995139</b>
<b>Part No.</b>	<b>Description</b>	<b>Qty</b>
025 563	Ram wiper	1
025 770	O seal	1
32-99-1372	Piston seal	1
025 793	Ram seal	1
32-07-0035	Bonded seal	3

# WEBTOOL

## CUTTING EDGE TECHNOLOGY

Webtool specialises in engineering powerful hydraulic tools for cutting and gripping rope, cable and umbilicals. Models designed for use in subsea environments by ROV's, and surface applications in hostile environments.

- Wire rope cutters (WCS and WCOS) – capable of cutting steel wire rope up to 75mm diameter
- Wire Rope Cutters (RCV) – capable of cutting steel wire rope up to 190mm diameter
- Cable Cutters (HCV) – capable of cutting cable, umbilical and armoured flexible pipe lines up to 330mm diameter
- Softline Cutters (SL) – capable of cutting fibre ropes in various sizes
  - Wire Rope / Cable Grippers
    - Wire Rope Clamps
    - Automatic Shackles

### Application specific solutions

Our in house design and manufacturing capability means we can quickly and efficiently develop a solution to suit your particular application. Contact our engineering department to discuss how we can help.

Allspeeds Ltd, Royal Works, Atlas Street, Clayton-Le-Moors,  
Accrington, Lancashire, BB5 5LW, England

T: +44 (0)1254 615100

F: +44 (0)1254 615199

E: [info@allspeeds.co.uk](mailto:info@allspeeds.co.uk)

W: [www.allspeeds.co.uk](http://www.allspeeds.co.uk)