

WCS38D

WIRE ROPE CUTTER

WEBTOOL

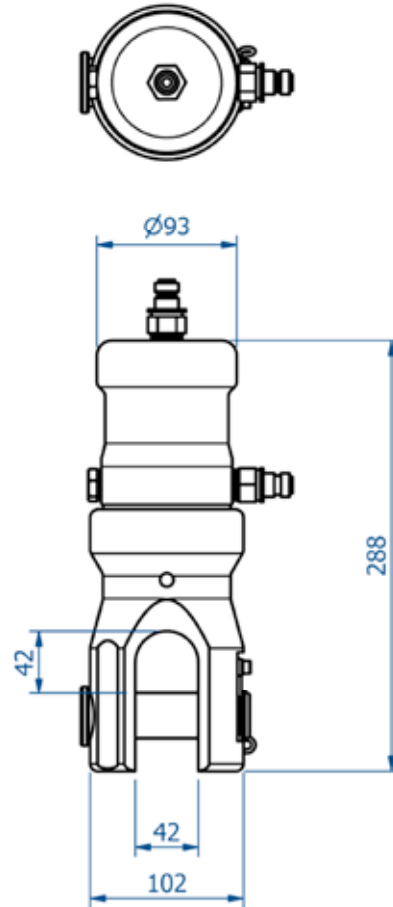

- Heavy duty wire rope cutter designed for use in severe working conditions
- Closed jaw design
- Anvil pin can be removed to allow the tool to be positioned on the cable
- Corrosion resistant stainless steel construction
- Long blade life ensures that tool maintenance is kept to a minimum
- Ideal for operation in confined spaces
- Optional intensifier panel is available
- Cutting capacity – Maximum $\varnothing 38\text{mm}$ wire rope of $1770\text{N}/\text{mm}^2$ grade
- Can be used at any water depth
- Suitable for cutting wire rope, cables and umbilicals
- 700 bar maximum input pressure
- Approx weight – 14.5kg
- Standard tool is shown above. Bespoke and custom designs to suit special applications are available on request



Northfield Hydraulic Services Limited
Suite 2 Riverside Business Centre
North Esplanade West
Aberdeen AB11 5RJ

Tel: +44 (0)1224 213 500
Fax: +44 (0)1224 213501
Email: info@n-h-s.co.uk

www.n-h-s.co.uk